



**Refrigerated Display Case**  
*Models RS-CN-0645*  
*Items 44254*  
**Instruction Manual**



*Revised - 06/08/2021*



Toll Free: 1-800-465-0234  
Fax: 905-607-0234  
Email: [service@omcan.com](mailto:service@omcan.com)  
[www.omcan.com](http://www.omcan.com)

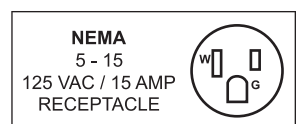

# ***Table of Contents***

Model RS-CN-0645

---

<b>Section</b>	<b>Page</b>
Disclaimer -----	3
General Information -----	4 - 5
Safety and Warranty -----	5 - 6
Technical Specifications -----	7
Installation -----	7 - 8
Operation -----	8 - 10
Maintenance -----	10 - 11
Troubleshooting -----	11 - 12
Parts Breakdown -----	13 - 14
Electrical Schematics -----	15
Notes -----	16 - 18
Warranty Registration -----	19

***OMCAN IS NOT RESPONSIBLE FOR ANY DAMAGES DUE TO WATER LEAKS. WARRANTY FOR WATER LEAKS IS VOID IF THE AMBIENT ROOM TEMPERATURE EXCEEDS 75°F AND 55% RELATIVE HUMIDITY, AND THE APPLIANCE DRAIN IS NOT CONNECTED DIRECTLY TO A FLOOR DRAIN.***

# General Information

---

Omcan Manufacturing and Distributing Company Inc., Food Machinery of America, Inc. dba Omcan and Omcan Inc. are not responsible for any harm or injury caused due to any person's improper or negligent use of this equipment. The product shall only be operated by someone over the age of 18, of sound mind, and not under the influence of any drugs or alcohol, who has been trained in the correct operation of this machine, and is wearing authorized, proper safety clothing. Any modification to the machine voids any warranty, and may cause harm to individuals using the machine or in the vicinity of the machine while in operation.

## CHECK PACKAGE UPON ARRIVAL

Upon receipt of an Omcan shipment please inspect for external damage. If no damage is evident on the external packaging, open carton to ensure all ordered items are within the box, and there is no concealed damage to the machine. If the package has suffered rough handling, bumps or damage (visible or concealed), please note it on the bill of lading before accepting the delivery and contact Omcan within 24 hours, so we may initiate a claim with the carrier. A detailed report on the extent of the damage caused to the machine must be filled out within three days, from the delivery date shown in the shipping documents. Omcan has no recourse for damaged products that were shipped collect or third party.

**Before operating any equipment, always read and familiarize yourself with all operation and safety instructions.**

Omcan would like to thank you for purchasing this machine. It's of the utmost importance to save these instructions for future reference. Also save the original box and packaging for shipping the equipment if servicing or returning of the machine is required.

---

Omcan Fabrication et distribution Compañie Limité et Food Machinery d'Amérique, dba Omcan et Omcan Inc. ne sont pas responsables de tout dommage ou blessure causé du fait que toute personne ait utilisé cet équipement de façon irrégulière. Le produit ne doit être exploité que par quelqu'un de plus de 18 ans, saine d'esprit, et pas sous l'influence d'une drogue ou d'alcool, qui a été formé pour utiliser cette machine correctement, et est vêtu de vêtements de sécurité approprié. Toute modification de la machine annule toute garantie, et peut causer un préjudice à des personnes utilisant la machine ou des personnes à proximité de la machine pendant son fonctionnement.

## VÉRIFIEZ LE COLIS DÈS RÉCEPTION

Dès réception d'une expédition d'Omcan veuillez inspecter pour dommages externes. Si aucun dommage n'est visible sur l'emballage externe, ouvrez le carton afin de s'assurer que tous les éléments commandés sont dans la boîte, et il n'y a aucun dommage dissimulé à la machine. Si le colis n'a subi aucune mauvaises manipulations, de bosses ou de dommages (visible ou cachée), notez-le sur le bond de livraison avant d'accepter la livraison et contactez Omcan dans les 24 heures qui suivent, pour que nous puissions engager une réclamation auprès du transporteur. Un rapport détaillé sur l'étendue des dommages causés à la machine doit être rempli dans un délai de trois jours, à compter de la date de livraison indiquée dans les documents d'expédition. Omcan n'a aucun droit de recours pour les produits endommagés qui ont été expédiés ou cueilli par un tiers transporteur.

# General Information

---

Avant d'utiliser n'importe quel équipement, toujours lire et vous familiariser avec toutes les opérations et les consignes de sécurité.

Omcan voudrais vous remercier d'avoir choisi cette machine. Il est primordial de conserver ces instructions pour une référence ultérieure. Également conservez la boîte originale et l'emballage pour l'expédition de l'équipement si l'entretien ou le retour de la machine est nécessaire.

---

Omcan Empresa De Fabricacion Y Distribucion Inc. Y Maquinaria De Alimentos De America, Inc. dba Omcan y Omcan Inc. no son responsables de ningun daño o perjuicio causado por cualquier persona inadecuada o el uso descuidado de este equipo. El producto solo podra ser operado por una persona mayor de 18 años, en su sano juicio y no bajo alguna influencia de droga o alcohol, y que este ha sido entrenado en el correcto funcionamiento de esta máquina, y ésta usando ropa apropiada y autorizada. Cualquier modificación a la máquina anula la garantía y puede causar daños a las personas usando la máquina mientras esta en el funcionamiento.

## REVISE EL PAQUETE A SU LLEGADA

Tras la recepcion de un envio Omcan favor inspeccionar daños externos. Si no hay daños evidentes en el empaque exterior, Habra el carton para asegurarse que todos los articulos solicitados estén dentro de la caja y no encuentre daños ocultos en la máquina. Si el paquete ha sufrido un manejo de poco cuidado, golpes o daños (visible o oculto) por favor anote en la factura antes de aceptar la entrega y contacte Omcan dentro de las 24 horas, de modo que podamos iniciar una reclamación con la compañía. Un informe detallado sobre los daños causados a la máquina debe ser llenado en el plazo de tres días, desde la fecha de entrega que se muestra en los documentos de envío. Omcan no tiene ningun recurso por productos dañados que se enviaron a recoger por terceros.

Antes de utilizar cualquier equipo, siempre lea y familiarizarse con todas las instrucciones de funcionamiento y seguridad.

Omcan le gustaría darle las gracias por la compra de esta máquina. Es de la mayor importancia para salvar estas instrucciones para futuras consultas. Además, guarda la caja original y el embalaje para el envío del equipo si servicio técnico o devolución de la máquina que se requiere.

# Safety and Warranty

---

1. This unit is a showcase refrigeration, objects placed in this unit should already be cooled.
2. This instruction manual must be read before operating the unit and must be kept for future reference.
3. **WARNING:** Never use this unit for applications which are not described in the instructions or under conditions which are not similar to those described in the instructions. Otherwise, sever injuries may occur.
4. This unit should only be used for the purpose for which it was designed. Any other use is inappropriate and therefore dangerous. Omcan will not be held responsible for any damage caused by improper use.
5. Before installing and operating the machine, carefully read this manual.

# ***Safety and Warranty***

---

6. Keep the unit out of reach of children. Do not allow children to play with the unit.
7. Unplug the unit from the outlet when not in use, before assembly or disassembly and before cleaning.
8. Be sure to unplug the unit if not using for a long period of time.
9. If the supply cord is damaged, the cord should be replaced by the manufacturer, authorized service agent or similarly qualified persons.
10. Do not use the unit in a dusty environment or flammable or explosive substances.
11. Disable the unit immediately if defective. Dispose of the unit according to the regulations of local law. Please see instructions for disposal in this manual.
12. Other than cleaning mentioned in this instruction manual, no additional maintenance or servicing of this unit is required.
13. The motor is permanently lubricated and will require no oil.
14. Repairs, when necessary, must be performed at an authorized service facility.
15. The unit is suitable for indoor use only.
16. Basic safety rules:
  - Do not touch the unit when hands or feet are wet.
  - Do not use the unit when barefoot.
  - Do not allow the unit to be used by children or untrained persons.
  - Do not leave the unit outside.
  - Do not pull on the electrical cord when unplugging the unit.
  - Omcan reserves the right to modify the construction or appearance of the unit without notice.

**RESIDENTIAL USERS: Vendor assumes no liability for parts or labor coverage for component failure or other damages resulting from installation in non-commercial or residential applications. The right is reserved to deny shipment for residential usage; if this occurs, you will be notified as soon as possible.**

## **1 YEAR PARTS AND LABOUR WARRANTY**

**Within the warranty period, contact Omcan Inc. at 1-800-465-0234 to schedule an Omcan authorized service technician to repair the equipment locally.**

**Unauthorized maintenance will void the warranty. Warranty covers electrical and part failures, not improper use.**

**Please see <https://omcan.com/disclaimer> for complete info.**

### **WARNING:**

The packaging components are classified as normal solid urban waste and can therefore be disposed of without difficulty.

**In any case, for suitable recycling, we suggest disposing of the products separately (differentiated waste) according to the current norms.**

**DO NOT DISCARD ANY PACKAGING MATERIALS IN THE ENVIRONMENT!**

# Technical Specifications

<b>Model</b>	<b>RS-CN-0645</b>
<b>Capacity</b>	645 L / 22.7 cu. ft.
<b>Max Ambient Temp Rating</b>	32°C / 90°F
<b>Temperature</b>	2°C - 9°C / 36°F - 48°F
<b>Compressor</b>	2/3 HP
<b>Amps</b>	8.5A
<b>Number of Shelves</b>	4
<b>Electrical</b>	115V / 60Hz / 1
<b>Dimensions</b>	59" x 29.5" x 54" / 1499 x 749 x 1372mm
<b>Weight</b>	628 lbs. / 285 kgs.
<b>Item Number</b>	44254

## Installation

### TRANSPORTATION

1. In order to prevent the oil contained in the compressor from flowing into the cooling circuit, it is necessary to always carry, store and handle the unit in a vertical position and follow the instructions found on the packaging.
2. If the unit was accidentally or purposely placed in a non-vertical position during transport, before operating the unit, keep the unit in a vertical position for approximately 24 hours, to allow the oil to flow back into the compressor.

### UNPACKING

Remove the wooden case board and plastic covering. Make sure that the unit has not been damaged. Remove the plastic film from all the stainless steel panels if applicable.

**IMPORTANT: The packaging should be kept away from children as it is potentially dangerous. Dispose of the packaging according to the regulations from the local authorities.**

### POSITIONING

1. Never clean the unit with pressurized water jets.
2. Place the unit on a flat and stable surface.
3. Install the unit in a location where it can be overseen by trained personnel.
4. For good ventilation, keep a distance of 20 cm (7 inches) between unit and walls or other objects. Increase the distance if the objects are a heating source. When the dispenser is in place, press the brake on the

# *Installation*

---

wheels in order to keep it from moving.

## **ASSEMBLY**

1. Fix the shelves on the unit.

## **ELECTRICAL CONNECTION**

Before inserting the plug into the electrical socket, carefully read the following precautions:

1. Make sure that the unit is properly connected to an properly grounded outlet, in compliance with current safety standards.
2. Make sure that the voltage is in accordance with what is indicated on the rating label.
3. The current available is sufficient for the maximum required by the unit.
4. If necessary, use multiple outlets which are properly grounded, in compliance with current safety standards. If in doubt, only consult qualified technicians.

**THE REFRIGERATED SHOW CASE MUST BE CONNECTED TO AN ELECTRICAL SOCKET WITH A GROUND.**

# *Operation*

---

Before using, the unit should be completely cleaned as it comes into contact with food.

1. Make sure that the main switch is in the (I) position, then plug in the unit.
2. Before starting the unit, ensure the sliding doors are properly closed.
3. Turn the main switch to the (I) position, the condensing unit will automatically start.
4. For lighting, press the lighting button. The lighting button is located on the thermostat.
5. If there is some condensation in front of the curved glass, please turn the switch to (I) position for defogging.
6. Allow the unit to reach proper temperature before loading with product.

## **WORKING TEMPERATURE ADJUSTMENT**



To reset the temperature inside the showcase, please follow as below:

**CAUTION: You are suggested not to reset the temperature controller frequently.**

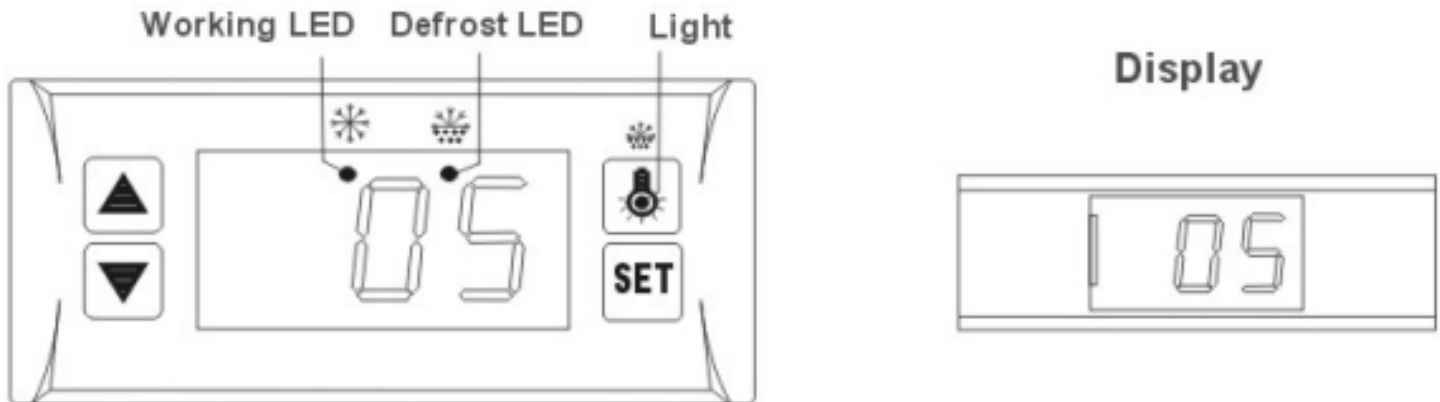

# Operation



1. Set Temperature
  - Press the SET button, the set temperature is displayed.
  - Press the ▲ or ▼ button to modify and store the display value, press the SET button to exit and display the cold room temperature.
  - If no button is pressed within 10 seconds, the cold room temperature will be displayed.
2. Illumination: Press  button, it lights. Press it again and it will stop.
3. Manual start/stop defrost: Press  and hold for 6 seconds to defrost or stop defrost.
4. Display Evaporation temperature: Press ▲ button and hold for 6 seconds, the evaporation temperature is displayed. After 10 seconds, the cold room temperature will be displayed.
5. Working LED: During the course of refrigeration, the LED is on. When the cold room temperature is constant, the LED is off. During the delay start, the LED flashes.
6. Defrost LED: during defrosting, the LED is on. When it stops defrosting the LED is off. During the delay display of defrost, the LED flashes.
7. Parameter Setup:
  - Press the SET button and hold for 6 seconds to enter the parameter setup mode while E1 flashes.
  - Press SET again to select sequential from the 10 parameters: E1, E2, E3, E4, E4, E5, F1, F2, F3, F4.
  - Press the ▲ or ▼ button, the different parameters will be displayed and can be modified and stored.
  - If no more buttons are pressed within 10 seconds, the cold room temperature will be displayed.

# Operation

---

Parameter	Function	Set Range
E1	Lower set point limit.	-45°C ~ Set temp.
E2	Higher set point limit.	Set temp. ~ 45°C.
E3	Temp. hysteresis.	1 - 10°C.
E4	Comp. start delay time.	0 - 10 mins.
E5	Offset on room temp.	-5 - 5°C.
E6	Offset on evap. temp.	-5 - 5°C.
F1	Max. defrost duration.	1 - 60 min.
F2	Defrost interval time.	0 - 24 Hr.
F3	Defrost termination temp.	0 - 20°C.
F4	Display during defrost.	0 = normal display. 1 = last value before defrost.

# Maintenance

---

## CLEANING

For health standards and good quality of beverages or foods, clean interiors of the unit as often as possible.

**CAUTION: Do not clean the unit by means of a water jet or pressurized washer.**

1. Before carrying out cleaning, turn the unit off and remove the power plug.
2. Do not use abrasive powders that might damage the interior parts of the showcase.
3. Use neutral soap and warm water to wash the interiors. Rinse carefully with water in order to remove any soap residues.
4. To maintain a high standard of working performance, leave the unit turned on during the night and day to avoid deposits.

**CAUTION: Do not use any damaging solvents (petrol, alcohol, etc.) for cleaning the unit. The unit may get damaged. Do not use and sharp objects for cleaning. The unit may be cleaned with a damp towel but should never directly come in contact with water. After cleaning the unit, make sure all parts are dried completely.**

## INSTRUCTIONS FOR DISPOSAL

When replacing your old unit with a new one, comply with the following information: Old units are not to be disposed of as regular waste. Valuable raw materials can be obtained by recycling old units.

**Render your old unit unusable:**

1. Cut off and remove the main power plug from the unit, then discard separately.

# Maintenance

**Caution:** Substances and gases in the thermal insulation must be disposed of professionally. Ensure that refrigeration tubing is not damaged prior to disposal. Please discard the unit according to the regulations of local law.

## Troubleshooting

Symptom	Possible Reasons	Solution	Remark
No power input/power direction lamp does not light.	Broken fuse.	Replace.	As for authorized service department to check and repair.
	Poor connection of plug and socket.	Repair or replace the socket.	
	Failure in input control circuit.		
Compressor does not work.	Thermostat does not work.	Replace.	
	Thermostat is not on the working position.	Turning to the working position.	
	Poor contract of thermostat.	Insert the plug tightly.	
	Loose plug pins in the starter.	Insert the plug tightly.	
	Broken compressor.	Replace.	
	Broken starter or capacitor.	Repair or replace.	

# Troubleshooting

Compressor runs, but the temperature in the showcase is high.	Circulating temperature is too high.	Adjust the thermostat properly.	Ask for authorized service department to check and repair it.
	Too much dust and dirt on the condenser.	Clean it on time.	
	Frost on the evaporator is too thick.	Stop the machine to defrost. Set the temperature higher.	
	Thermostat is out of work.	Replace.	
Condenser fan does not run.	The capacitor of the fan is out of work.	Replace.	
	The ball-bearing of the fan motor lacks oil.	Fill oil.	
	The winding of the fan motor is damaged.	Replace.	
Compressor starts/stops frequently.	The winding of the compressor is short circuit.	Check with a multi meter, replace the compressor.	
	Poor contact of the socket.	Repair or replace.	
The fan of the evaporator does not work.	The fan motor is damaged.	Replace.	

**Warning: If the machine has any problems or has been damaged, do not try to repair or replace it by yourself. Please contact Omcan technical service at 1-800-465-0234.**

# Parts Breakdown

Model RS-CN-0645 44254

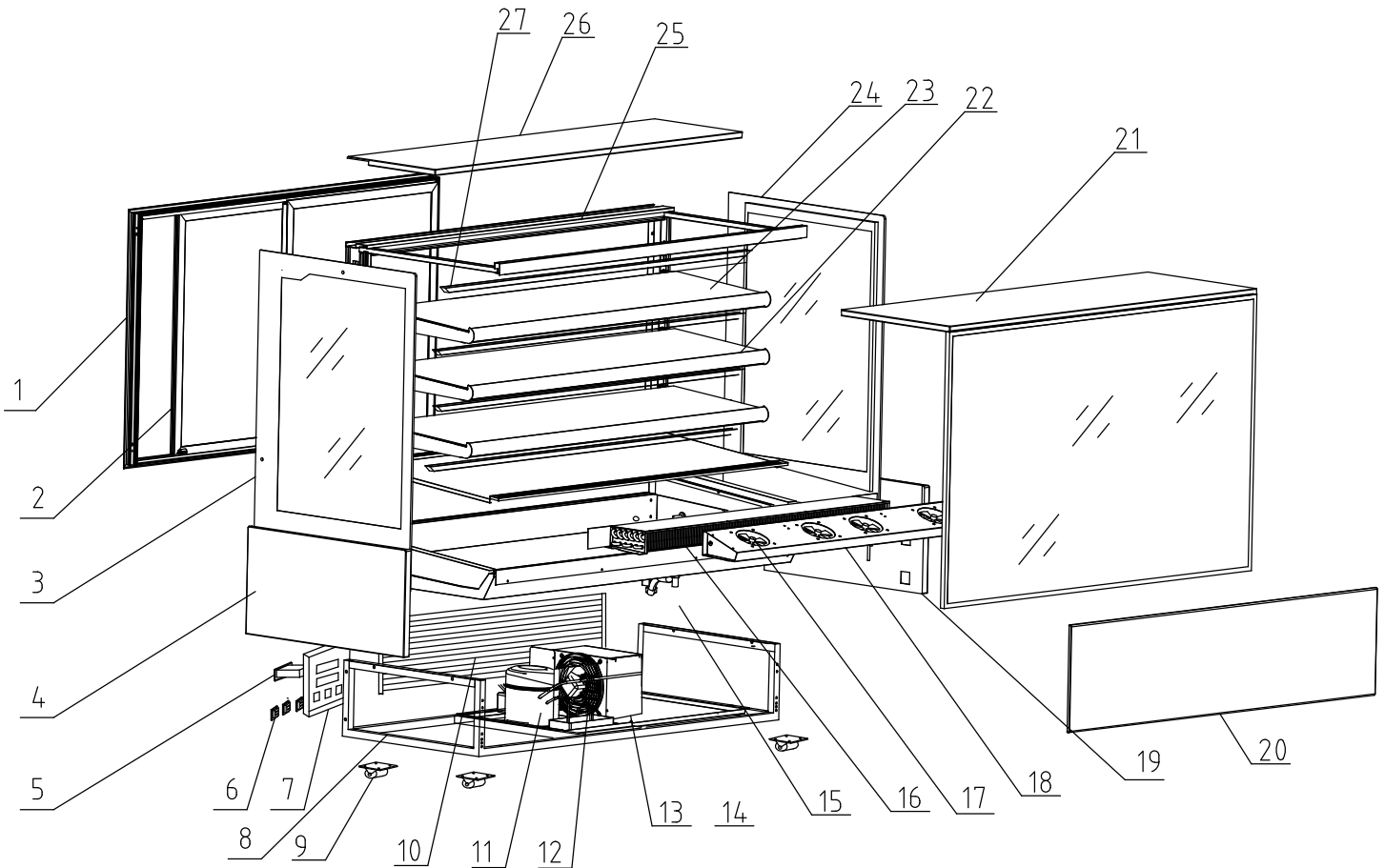

# Parts Breakdown

---

## Model RS-CN-0645 44254

Item No.	Description	Position	Item No.	Description	Position	Item No.	Description	Position
66070	Door Frame for 44254	1	64104	Rear Air Grill Backboard for 44254	10	66077	Right Panel for 44254	19
64103	Sliding Door for 44254	2	64101	Compressor for 44254	11	64111	Evaporator Cover for 44254	20
64095	Left Side Glass for 44254	3	66074	Condenser Fan for 44254	12	64094	Front Glass for 44254	21
66071	Left Panel for 44254	4	64113	Condenser for 44254	13	64105	Shelf for 44254	22
64099	Digital Thermostat for 44254	5	66075	Water Box for 44254	14	66079	Shelf Glass for 44254	23
64100	Switch for 44254	6	64106	Front Air Grill for 44254	15	66080	Right Side Glass for 44254	24
66072	Control Panel for 44254	7	64112	Evaporator for 44254	16	66081	Body for 44254	25
66073	Under Frame for 44254	8	64110	Evaporator Fan for 44254	17	66082	Top Panel for 44254	26
64114	Caster Wheel for 44254	9	64102	Fan Ventilation Board for 44254	18	66083	Lamp for 44254	27

# Electrical Schematics

Model RS-CN-0645 44254

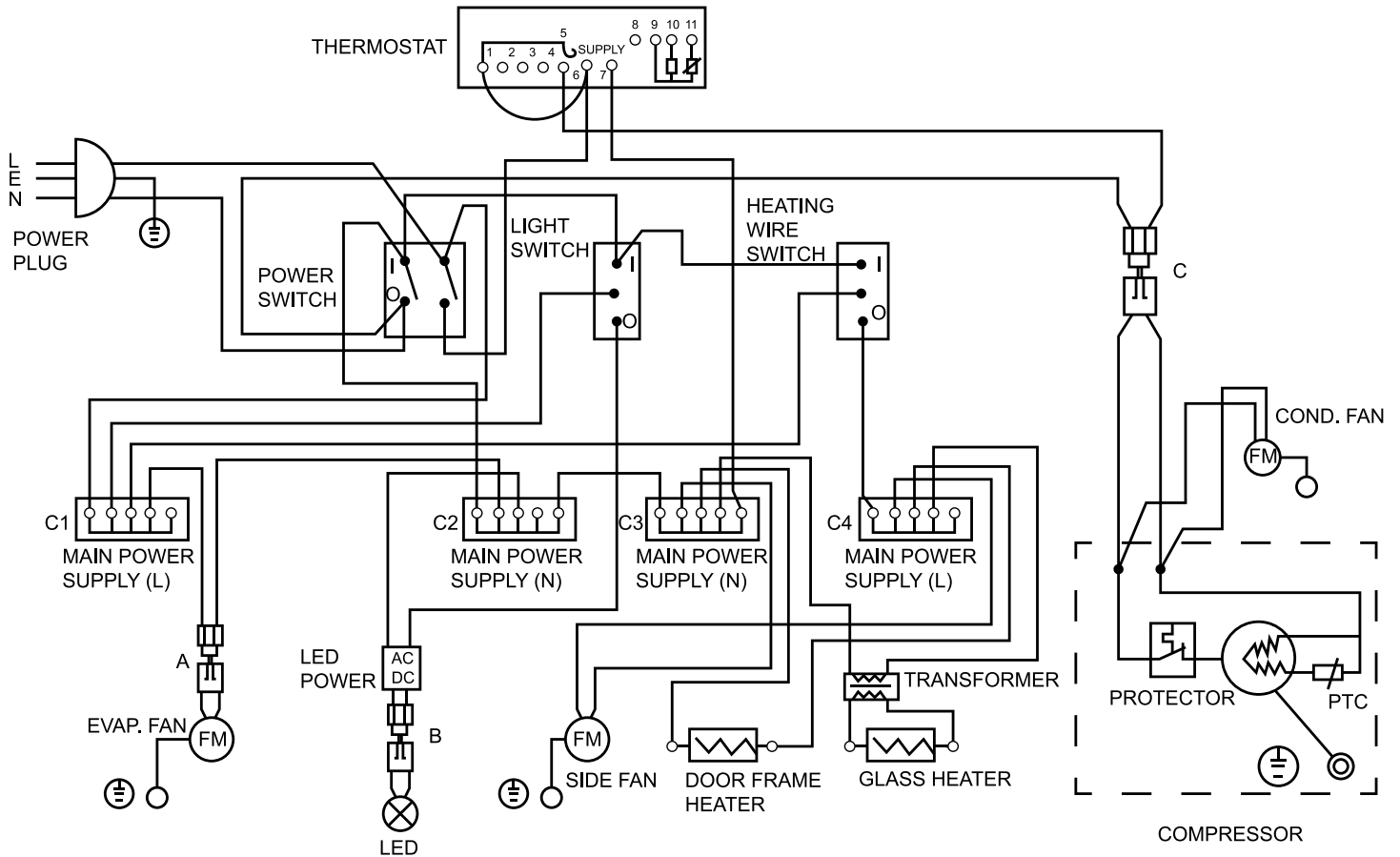

# Notes

---

---

---

---

---

---

---

---

---

---

---

---

---

---

---

---

---

---

---

---

---

---

---

---

---

---

---









# Warranty Registration

Thank you for purchasing an Omcan product. To register your warranty for this product, complete the information below, tear off the card at the perforation and then send to the address specified below. You can also register online by visiting:

Merci d'avoir acheté un produit Omcan. Pour enregistrer votre garantie pour ce produit, complétez les informations ci-dessous, détachez la carte au niveau de la perforation, puis l'envoyer à l'adresse spécifiée ci-dessous. Vous pouvez également vous inscrire en ligne en visitant:

Gracias por comprar un producto Omcan usted. Para registrar su garantía para este producto, complete la información a continuación, cortar la tarjeta en la perforación y luego enviarlo a la dirección indicada a continuación. También puede registrarse en línea en:

<https://omcan.com/warranty-registration/>

For mailing in Canada

Pour postale au Canada

Por correo en Canadá

**OMCAN**

PRODUCT WARRANTY REGISTRATION

3115 Pepper Mill Court,

Mississauga, Ontario

Canada, L5L 4X5

For mailing in the US

Pour diffusion aux États-Unis

Por correo en los EE.UU.

**OMCAN**

PRODUCT WARRANTY REGISTRATION

4450 Witmer Industrial Estates, Unit 4,

Niagara Falls, New York

USA, 14305

*or email to: [service@omcan.com](mailto:service@omcan.com)*



Purchaser's Information

Name: \_\_\_\_\_

Address: \_\_\_\_\_

City: \_\_\_\_\_ Province or State: \_\_\_\_\_ Postal or Zip: \_\_\_\_\_

Country: \_\_\_\_\_

Dealer from which Purchased: \_\_\_\_\_

Dealer City: \_\_\_\_\_ Dealer Province or State: \_\_\_\_\_

Invoice: \_\_\_\_\_

Model Name: \_\_\_\_\_ Model Number: \_\_\_\_\_

Machine Description: \_\_\_\_\_

Date of Purchase (MM/DD/YYYY): \_\_\_\_\_

Would you like to extend the warranty?  Yes  No

Company Name: \_\_\_\_\_

Telephone: \_\_\_\_\_

Email Address: \_\_\_\_\_

Type of Company:

Restaurant  Bakery  Deli

Butcher  Supermarket  Caterer

Institution (specify): \_\_\_\_\_

Other (specify): \_\_\_\_\_

Serial Number: \_\_\_\_\_

Date of Installation (MM/DD/YYYY): \_\_\_\_\_

**Thank you for choosing Omcan | Merci d'avoir choisi Omcan | Gracias por elegir Omcan**



Since 1951 Omcan has grown to become a leading distributor of equipment and supplies to the North American food service industry. Our success over these many years can be attributed to our commitment to strengthen and develop new and existing relationships with our valued customers and manufacturers. Today with partners in North America, Europe, Asia and South America, we continually work to improve and grow the company. We strive to offer customers exceptional value through our qualified local sales and service representatives who provide convenient access to over 5,000 globally sourced products.

---

Depuis 1951 Omcan a grandi pour devenir un des “leaders” de la distribution des équipements et matériel pour l’industrie des services alimentaires en Amérique du Nord. Notre succès au cours de ces nombreuses années peut être attribué à notre engagement à renforcer et à développer de nouvelles et existantes relations avec nos clients et les fabricants de valeur. Aujourd’hui avec des partenaires en Amérique du Nord, Europe, Asie et Amérique du Sud, nous travaillons continuellement à améliorer et développer l’entreprise. Nous nous efforçons d’offrir à nos clients une valeur exceptionnelle grâce à nos ventes locales qualifiées et des représentants de service qui offrent un accès facile à plus de 5000 produits provenant du monde entier.

---

Desde 1951 Omcan ha crecido hasta convertirse en un líder en la distribución de equipos y suministros de alimentos en América del Norte industria de servicios. Nuestro éxito en estos años se puede atribuir a nuestro compromiso de fortalecer y desarrollar nuevas relaciones existentes con nuestros valiosos clientes y fabricantes. Hoy con socios de América del Norte, Europa, Asia y América del Sur, que trabajan continuamente para mejorar y crecer la empresa. Nos esforzamos por ofrecer a nuestros clientes valor excepcional a través de nuestro local de ventas y representantes de los servicios que proporcionan un fácil acceso a más de 5,000 productos con origen a nivel mundial.

